

# POWER RELAY

## 1 POLE - 5A Change Over Relay

### FTR-F3 Series

#### ■ FEATURES

- High density mounting  
Height: 15mm  
Mounting space: 164mm<sup>2</sup>
- High insulation  
Insulation distance: 7mm between coil and contacts (conforms to IEC 60065)  
Dielectric strength: 4KV  
Surge strength: 10KV
- Cadmium free contact for eco-program
- Safety standards  
UL, CSA, VDE
- Plastic sealed relay, RTIII
- RoHS compliant  
Please see page 6 for more information

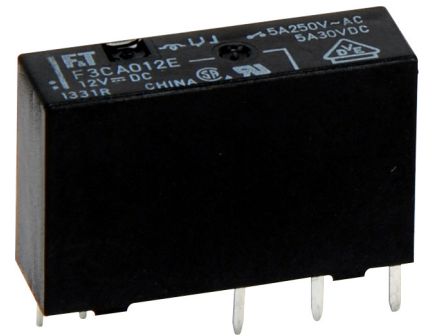

#### ■ Part Numbers

[Example]    FTR-F3    C    A    012    E  
                   (a)    (b)    (c)    (d)    (e)

(a)	Relay type	FTR-F3: FTR-F3 series
(b)	Contact configuration	C: 1 form C
(c)	Coil type (power)	A: 360mW
(d)	Coil rated voltage	012: 5..... 24VDC Coil rating table at page 3
(e)	Contact material	E: AgNi

Actual marking does not carry the type name: "FTR"  
 E.g.: Ordering code: FTR-F3CA012E Actual marking: F3CA012E

# FTR-F3 Series

## ■ Specifications

Item			FTR-F3	Remarks / conditions	
Contact data	Configuration		1 form C		
	Construction		Single		
	Material		AgNi		
	Resistance		Max. 100mOhm	Initial at 1A, 6VDC	
	Contact rating		5A, 250VAC, 30VDC	Resistive	
	Max. carrying current		5A		
	Max. switching voltage		277VAC, 30VDC		
	Max. switching power		1,250VA, 150W		
	Min. switching load *1		10 mA, 5VDC		
Coil	Rated power (20°C)		360mW		
	Operating temperature range		-40°C ~ +70°C (at rated voltage)	No frost	
Timing data	Operate		Max. 10ms	without bounce	
	Release		Max. 10ms	without bounce	
Life	Mechanical		Min. 2 x 10 <sup>6</sup> operations		
	Electrical (resistive)		Min. 100 x 10 <sup>3</sup> operations (3A, 250VAC/30VDC) Min. 50 x 10 <sup>3</sup> operations (5A, 250VAC/30VDC)	At rated load	
Insulation	Insulation resistance		Min. 1000MΩ at 500VDC		
	Dielectric strength	Open contacts	750VAC (50/60Hz), 1 minute		
		Coil contact	4000VAC (50/60Hz), 1 minute		
	Surge strength	Coil to contacts	10,000V / 1.2 x 50μs standard wave		
	Clearance		7mm		
	Creepage		7mm		
	EN61810-1, VDE0435	Voltage		250V	
		Pollution		2	
Material group		III			
Other	Vibration resistance	Misoperation	10Hz ~ 55Hz ~ 10Hz single amplitude 0.75mm		
		Endurance	10Hz ~ 55Hz ~ 10Hz single amplitude 0.75mm		
	Shock resistance	Misoperation ≥1us	Min. 100m/s <sup>2</sup> (11 ± 1ms)		
		Endurance	Min. 1,000m/s <sup>2</sup> (6 ± 1ms)		
	Dimensions / weight		7.0 x 23.4 x 15.0 mm / approx. 6g		
	Sealing		Plastic sealed RTIII		

\*1: Minimum switching loads mentioned above are reference values. Please perform the confirmation test with actual load before production since reference values may vary according to switching frequencies, environmental conditions

# FTR-F3 Series

## ■ Coil Data

Coil code	Rated Coil Voltage (VDC)	Coil Resistance +/-10%(Ω)	Must Operate Voltage* (VDC)	Must Release Voltage* (VDC)	Rated Power (mW)
005	5	69	3.75	0.5	360
006	6	100	4.5	0.6	
009	9	225	6.75	0.9	
012	12	400	9	1.2	
018	18	900	13.5	1.8	
024	24	1,600	18	2.4	

Note: All values in the table are valid at 20°C and zero contact current, unless otherwise specified.

\*: Specified operated values are valid for pulse wave voltage.

Note: Please use at rated coil voltage. Please refer to characteristic data and set up adequate voltage in case of use at over voltage.

## ■ Safety Standards

Type	Compliance	Contact rating
UL	UL 508 File No. E63614	Flammability: UL 94-V-0 (plastics)
		5A, 30VDC / 250VAC (resistive) 3A, 30VDC / 250 VAC (resistive)
CSA	C22.2 No. 14 File No. LR 40304	5A, 250 VAC, $\cos\phi=1$ 5A, 30 VDC L/R=0ms 3A, 250 VAC, $\cos\phi=1$ 3A, 30 VDC L/R=0ms
VDE	IEC/EN61810-1 EN60065 clause 14.6.1	
CQC	GB15092.1 / GB/T21811.1 17002164382, 04001010925	5A 250VAC / 30VDC

# FTR-F3 Series

## ■ Characteristic Data (Reference)

\* Characteristic data is not guaranteed value but measured values of samples from production line.

Coil Temperature Rise

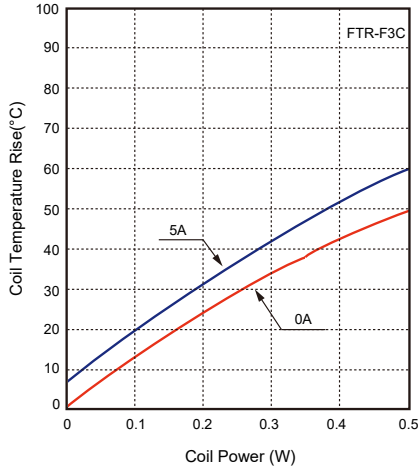

Operating Range

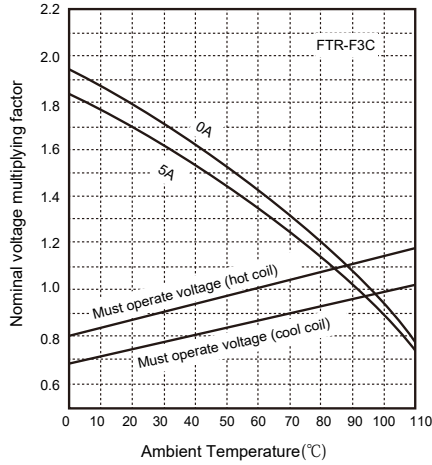

Maximum Switching Power

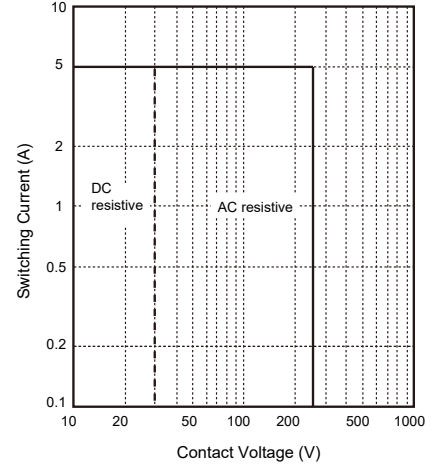

Life Curve

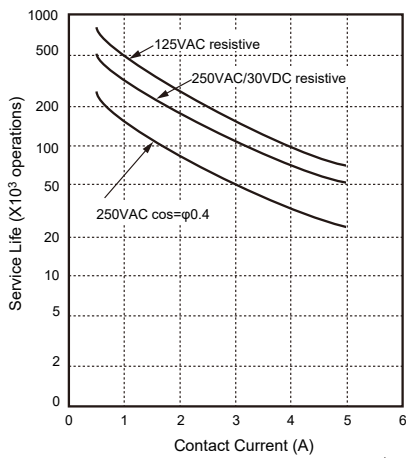

Distribution of Contact Resistance (N.O.)

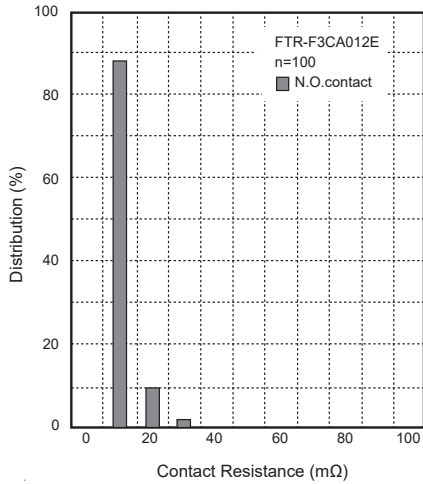

Distribution of Contact Resistance (N.C.)

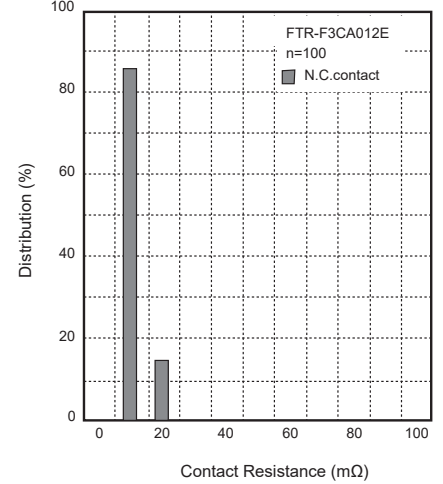

Distribution of Operation & Release Voltage

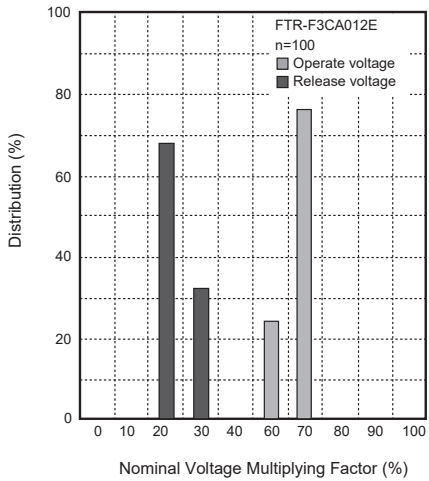

Distribution of Operation Time

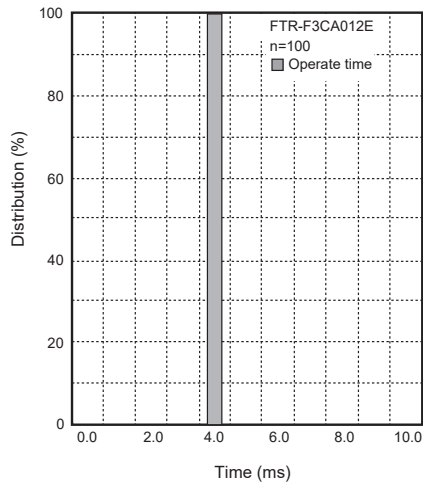

Distribution of Release Time

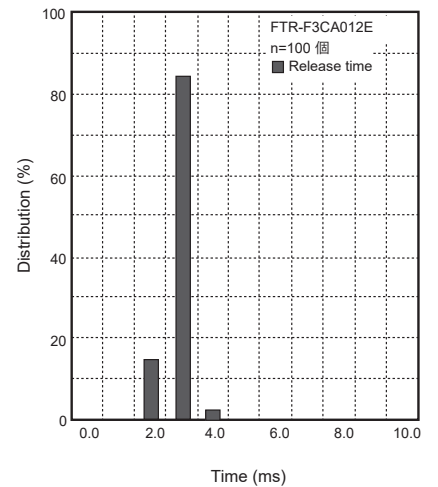

# FTR-F3 Series

## ■ Dimensions

- Dimensions: Changeover contact type

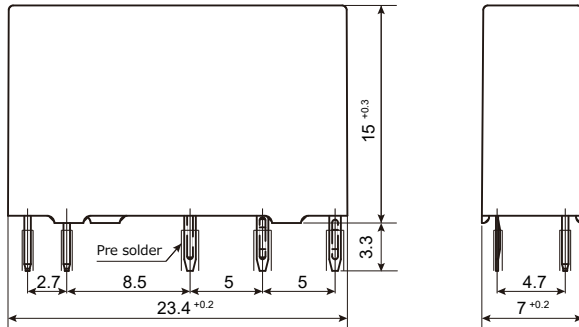

\* Dimensions of the terminals do not include thickness of pre-solder.

- Schematics  
(BOTTOM VIEW)

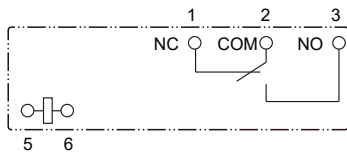

- PC Board Mounting Hole  
Layout (BOTTOM VIEW)

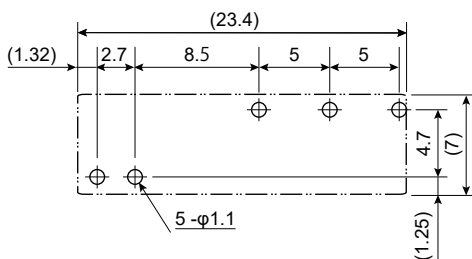

( ): Reference  
value Unit: mm

\* Tolerance of PC board mounting hole layout :  $\pm 0.1$  unless otherwise specified.

# FTR-F3 Series

## CAUTIONS

- All values mentioned in this datasheet are provided under ideal conditions. Please perform the confirmation test before actual use.
- Reflow soldering is prohibited.
- Do not use relays in the atmosphere with sulfide gas, chloride gas or nitric oxide. Contact resistance may increase.
- Do not use silicon or silicon-containing product or materials near relays. It may cause contact failure.

## GENERAL INFORMATION

### 1. RoHS Compliance

- All relays produced by FCL Components are compliant with RoHS directive 2011/65/EU, including commission-delegated directive 2015/863.

### 2. Recommended Lead Free Solder Condition

- Lead free solder plating on relay terminals is Sn-3.0Ag-0.5Cu, unless otherwise specified. This material has been verified to be compatible with PbSn assembly process.
- Recommended solder for assembly: Sn-3.0Ag-0.5Cu.

#### Flow Solder Condition:

Pre-Heating: Maximum 120°C within 90 sec.  
Soldering: Dip within 5 sec. at 255°C±5°C solder bath  
Relay must be cooled by air immediately after soldering

#### Solder by Soldering Iron:

Soldering iron: 30W to 60W  
Temperature: Maximum 340°C to 360°C  
Duration: Maximum 3 sec.

**We highly recommend that you confirm your actual solder conditions**

### 3. Moisture Sensitivity

- Moisture Sensitivity Level standard is not applicable to electromechanical relays, unless otherwise indicated.

### 4. Tin Whiskers

- Dipped SnAgCu solder is known as presenting a low risk to tin whisker development. No considerable length whisker was found by our in-house test.

---

## Contact

### Japan

FCL COMPONENTS LIMITED  
Shinagawa Seaside Park Tower  
12-4, Higashi-shinagawa 4-chome,  
Tokyo 140 0002, Japan  
Tel: +81-3-3450-1682  
Email: fcl-contact@cs.fcl-components.com

### North and South America

FCL COMPONENTS AMERICA, INC.  
2055 Gateway Place Suite 480,  
San Jose, CA 95110 USA  
Tel: +1-408-745-4900  
Email: fcai.components@fcl-components.com

### Europe

FCL COMPONENTS EUROPE B.V.  
Diamantlaan 25  
2132 WV Hoofddorp, Netherlands  
Tel: +31-23-556-0910  
Email: info.fceu@cs.fcl-components.com

### Asia Pacific

FCL COMPONENTS ASIA PTE LTD.  
No. 20 Harbour Drive, #07-01B  
Singapore 117612  
Tel: +65-6375-8560  
Email: fcal@fcl-components.com

### China

FCL COMPONENTS (SHANGHAI) CO., LTD.  
Unit 1105, Central Park - Jing An,  
No.329 Heng Feng Road, Shanghai 200070,  
China  
Tel: +86-21-3253 0998  
Email: fcsh@fcl-components.com

**Web:** [www.fcl-components.com/en/](http://www.fcl-components.com/en/)

---

© 2024 FCL Components Limited. All rights reserved. All trademarks or registered trademarks are the property of their respective owners.

FCL Products are intended for general use, including without limitation, in personal, household and office environments, in buildings and for ordinary use in the industry. FCL Products are not intended to be used in applications where extremely high safety is required ("High Safety Required Applications"), such as, but not limited to, applications in nuclear facilities, in aircraft automatic flight control, in air traffic control, in mass transit system control, in missile launch system, in weapon systems, in medical equipment for life support or any application involving a direct serious risk of physical injury or death.

Please do not use FCL Products without securing the sufficient safety and reliability required for the High Safety Required Applications. In addition, FCL shall not be liable against the customer and/or any third party for any claims or damages arising in connection with the use of FCL Products in the High Safety Required Applications.

FCL warrants that its Products, if properly used and services, will conform to their specification and will be free from defects in material and workmanship for twelve months from delivery.

The implied warranties of merchantability and fitness for a particular purpose and all other warranties, representations and conditions, express or implied by statute, trade usage or otherwise, except as set forth in this warranty, are excluded and shall not apply to the Products delivered.

The contents, data and information in this datasheet are provided by FCL Components Limited as a service only to its user and only for general information purposes. The use of the contents, data and information provided in this datasheet is at the users' own risk. FCL has assembled this datasheet with care and will endeavor to keep the contents, data and information correct, accurate, comprehensive, complete and up to date.

FCL Components Limited and affiliated companies do however not accept any responsibility or liability on their behalf, nor on behalf of its employees, for any loss or damage, direct, indirect or consequential, with respect to this datasheet, its contents, data, and information and related graphics and the correctness, reliability, accuracy, comprehensiveness, usefulness, availability and completeness thereof. Nor do FCL Components Limited and affiliated companies accept on their behalf, nor on behalf of its employees, any responsibility or liability with respect to these datasheets, its contents, data, information and related graphics and the correctness, reliability, accuracy, comprehensiveness, usefulness, availability and completeness thereof. Rev. February 1, 2024.

---